

BR HOME  
OREUM TABLE LAMP



STYLE # 6002863



SMALL OR MEDIUM OR LARGE OR EXTRA LARGE

**DIMENSIONS**

Small Height	12"
Small Base Width	5"
Medium Height	16"
Medium Base Width	6"
Large Height	23"
Large Base Width	7"
Extra Large Height	33"
Extra Large Base Width	9"

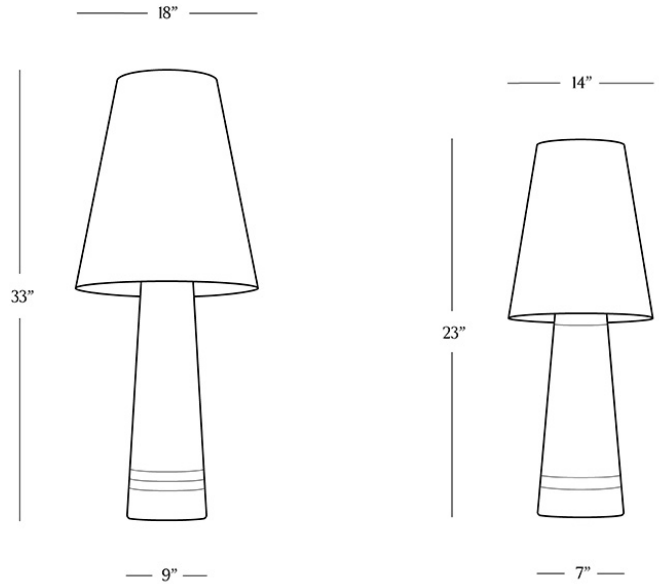

**RATING**

Max Wattage	60-watt maximum incandescent OR 13-watt maximum LED
Bulbs (Not Included)	Type A, E-26

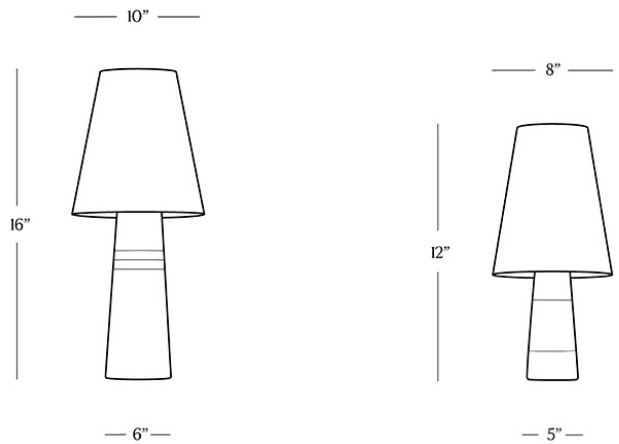

**PARTS ENCLOSED**

- (A) Lamp Base (1)
- (B) Saddle (1)
- (C) Harp (1)
- (D) Finial Screw Plate (1)
- (E) Shade (1)
- (F) Finial (1)
- (G) Lamp Holder (1)

---

SMALL OR MEDIUM OR LARGE OR EXTRA LARGE

## DETAILS

---

Luxe details and artisanal wood craftsmanship give our Oreum Floor Lamp its organic élan. Fashioned from solid mango and hammered by hand for rich texture, the conical design is inlaid with a trio of brass stripes that gleam against the ebony finish.

- Solid Mango wood with brass inlay
- Fabric shade (included)
- 8' fabric-wrapped cord
- Rocker on-off switch
- Made in India

## CARE

---

- UL Dry rated, not suitable for moist, outdoor, or wet environments
- Dust regularly with a soft, dry cloth or carefully vacuum using the upholstery attachment
- Avoid the use of harsh cleaners and abrasives which may damage the finish

## IMPORTANT SAFETY INSTRUCTIONS

---

PLEASE FOLLOW THE ASSEMBLY INSTRUCTIONS CLOSELY. IMPROPER ASSEMBLY OR INSTALLATION CAN RESULT IN PERSONAL OR PROPERTY DAMAGE.

### BULBS

This lamp has been rated for (1) 60-watt maximum Type A incandescent light bulb or (1) 13-watt maximum LED lightbulb. To avoid the risk of fire, do not exceed the recommended wattage.

## WARNINGS

---

All wires are connected. When unpacking, be careful not to pull wires, as damage may result. Do not connect electricity until the lamp is fully assembled. To reduce the risk of fire, electrical shock, or personal injury, always turn off lamp and allow it to cool prior to replacing the light bulb. Do not touch or look directly at the bulb when lamp is illuminated. Keep flammable materials away from lit bulb.

## WARNINGS: STRANGULATION HAZARD

---

Keep cord at least 3 feet away from cribs, bassinets, and toddler beds. Keep out of reach of children under 3 years of age.

THIS PRODUCT IS NOT A TOY AND HAS NO PLAY VALUE.

SMALL OR MEDIUM OR LARGE OR EXTRA LARGE

## ASSEMBLY

---

1. Carefully remove all parts from the box and remove all plastic coverings.
2. Insert harp (C) into the saddle (B).
3. Insert LED bulb (not included) into the lamp holder (G).
4. Remove the finial (F) by unscrewing in a counterclockwise direction.
5. Place the shade (E) on finial screw plate (D).
6. Reattach the finial (F) and tighten the shade by screwing in a clockwise direction.
7. Plug into proper electrical outlet and test lamp by turning it on.
8. Assembly is complete.